

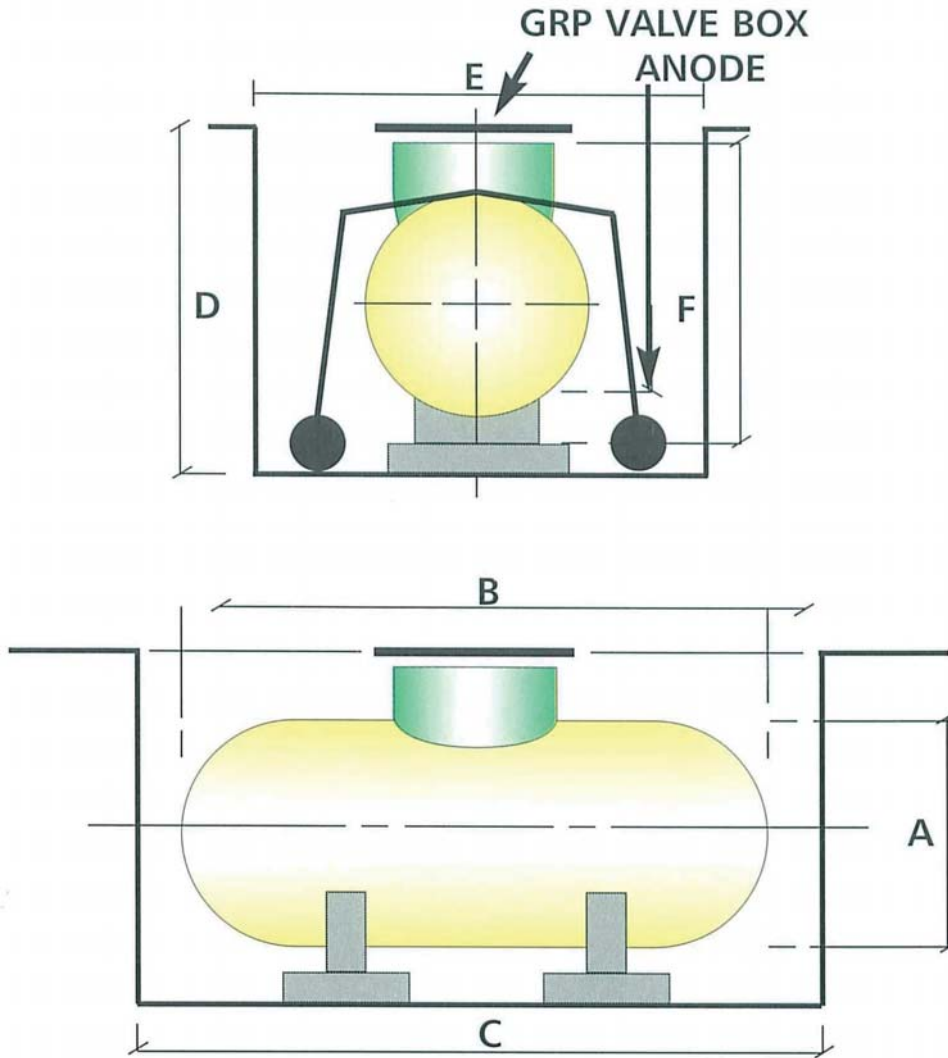

Energy Solutions

Under Ground 2000 Kilo Propane Tank



Safety Distances		Excavation Size		
Normal	Firewall	Depth	Width	Length
7.5m	4m	1.865m	2.2m	5.6m

Tank Dimensions				Vaporisation
Height	Width	Length	Weight	Btu/HR3
1.865m	1.2m	4.38m	1073Kg	510,000

Vessel Data	1000 Kilo
'A' Tank diameter (mm)	1200
'B' Tank Length (mm)	4388
'C' Excavation Length (mm)	5600
'D' Excavation Depth (mm)	1870
'E' Excavation Width (mm)	2200
'F' Tank Delivered Height (mm)	1620